

Linear Encoders

Angle Encoders

Rotary Encoders

3-D Touch Probes

Digital Readouts

Controls

Sealed Linear Encoders with Single-Field Scanning

HEIDENHAIN linear encoders are used as position measuring systems on machine tools, in handling and automation technology, and in measuring and inspecting equipment. Sealed linear encoders are protected from dust, chips and splash fluids and are ideal for operation on machines and systems with harsh operating environments in regard to contamination. Because of their compact design, they are

also very effective in direct drives and assembly automation. These additional areas of application expand the requirements on the sealed linear encoders. For example, linear motors require increased traversing speeds. Precision machines require high positioning accuracy, and an improved tolerance to contamination increases a machining center's availability.

With a fundamental revision of its incremental linear encoders, HEIDENHAIN is fulfilling these requirements-starting with their slimline versions. Here a scanning principle is applied to sealed linear encoder that is characterized by significantly reduced sensitivity to contamination, and higher quality of the output signal.

The advantages at a glance:

- Higher **positioning accuracy** and higher **traversing speed** thanks to improved signal quality
- Higher tolerance to **contamination**

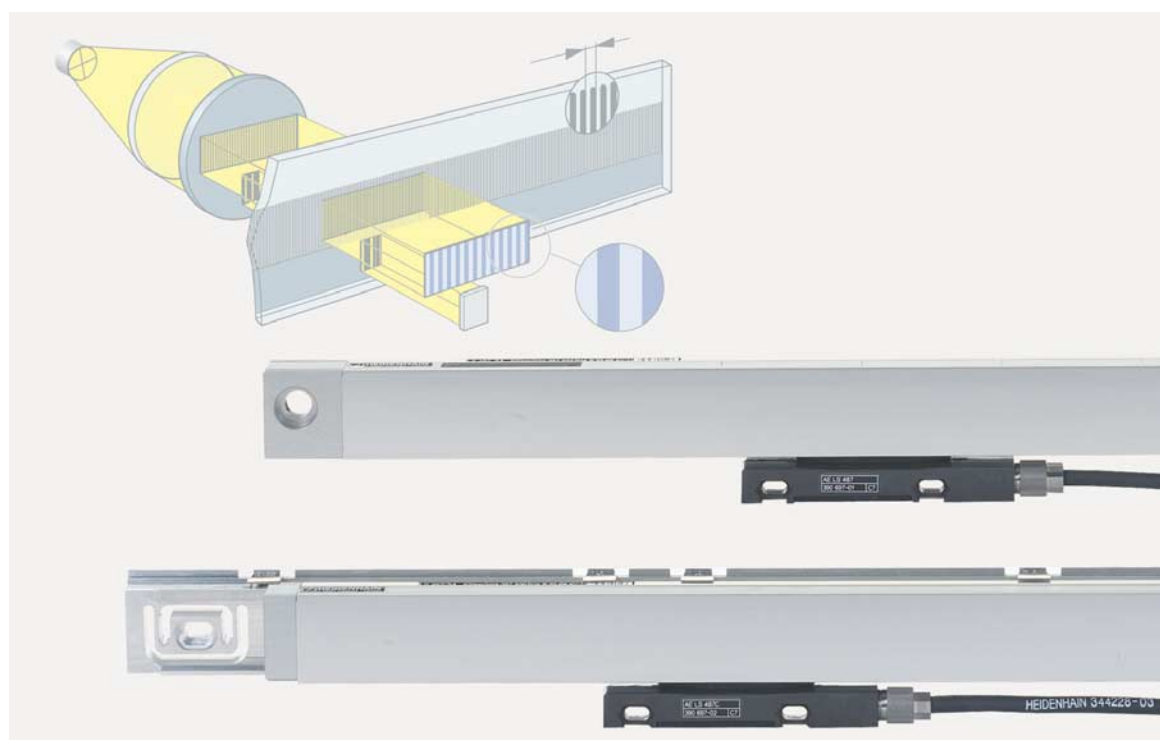

Scanning Principle

Photoelectric scanning

Like most HEIDENHAIN encoders, the linear encoders operate according to the principle of photoelectrically scanning a regularly structured measuring standard.

The type of scanning is crucial for the quality of the output signals and therefore both for the positioning accuracy and for traversing speed.

Optical systems are sensitive by nature to contamination of all types. With the new single-field scanning principle, which HEIDENHAIN is applying for the first time to a sealed linear encoder, it has become possible to improve both qualities decisively. This illustration compares it with the previous 4-field scanning.



The imaging scanning principle

In the imaging scanning principle, as it is used for example in the LS sealed linear encoders, a structured scale moves relative to an opposed grating—the index grating—with an identical or similar structure. The incident light is modulated: if the gaps are aligned, light passes through. If the lines of one grating coincide with the gaps of the other, no light passes through. Photocells convert these variations in light intensity into electrical signals.

Signal generation with 4-field scanning

The scanning reticle has scanning fields whose gratings are offset to one another by one fourth of a grating period each. The corresponding photocells generate sinusoidal signals, phase-shifted to one another by 90° (elec.). These scanning signals are not at first symmetrical about the zero line. For this reason the photovoltaic cells are connected in a push-pull circuit, producing two output signals I_1 and I_2 in symmetry with respect to the zero line and electrically phase-shifted by 90°.

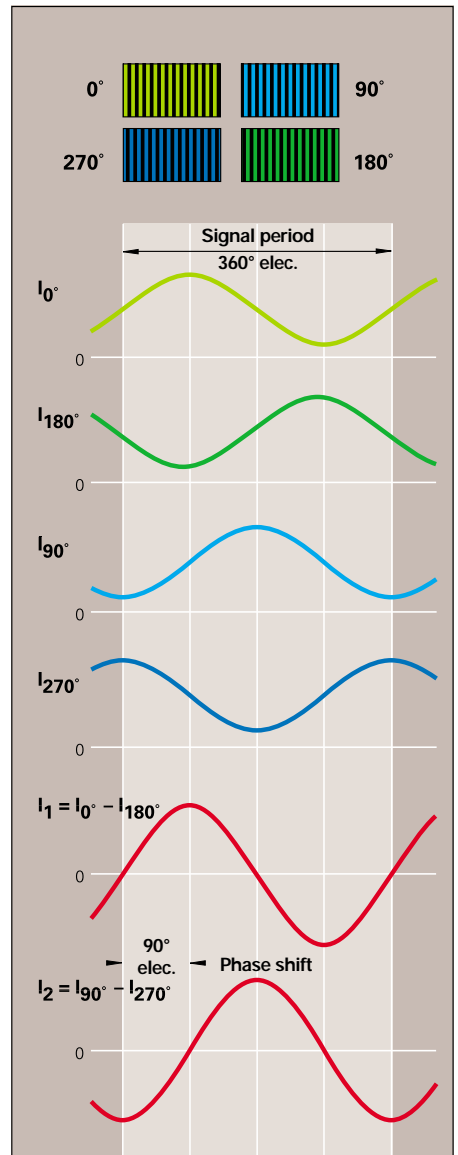
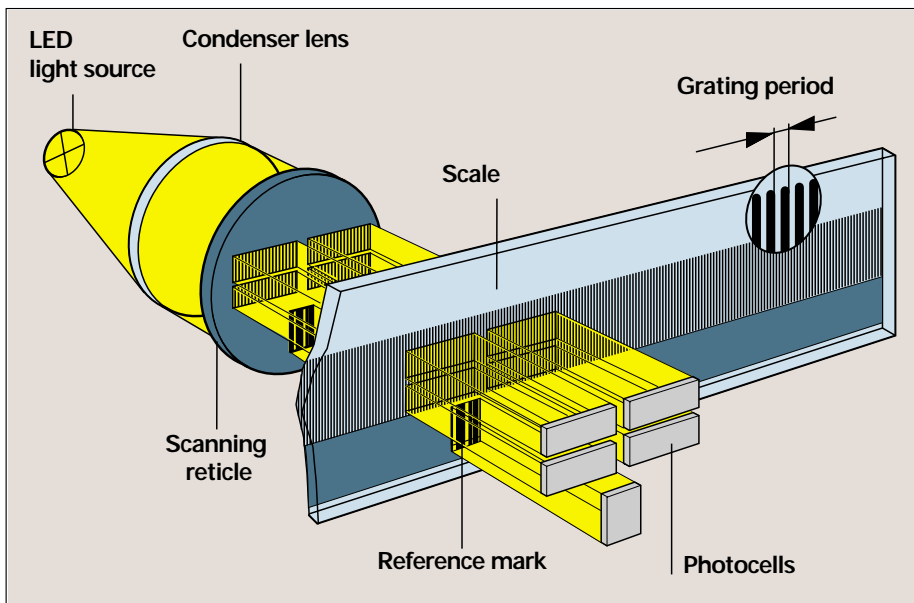

Photoelectric scanning in accordance with the imaging principle and 4-field scanning

Signal generation with single-field scanning

The scanning reticle has one large-area grating whose grating period differs slightly from that of the scale. This generates an optical beat along the length of the scanning field: at some positions the lines coincide and permit light through. At other locations the lines and gaps coincide, causing a shadow. In between, the gaps are only partially covered. This causes a type of optical filtering that allows homogeneous signals of a shape very close to a sine wave. Instead of individual photocells, one large-area, specially structured photosensor generates the four 90° electrically phase-shifted scanning signals.

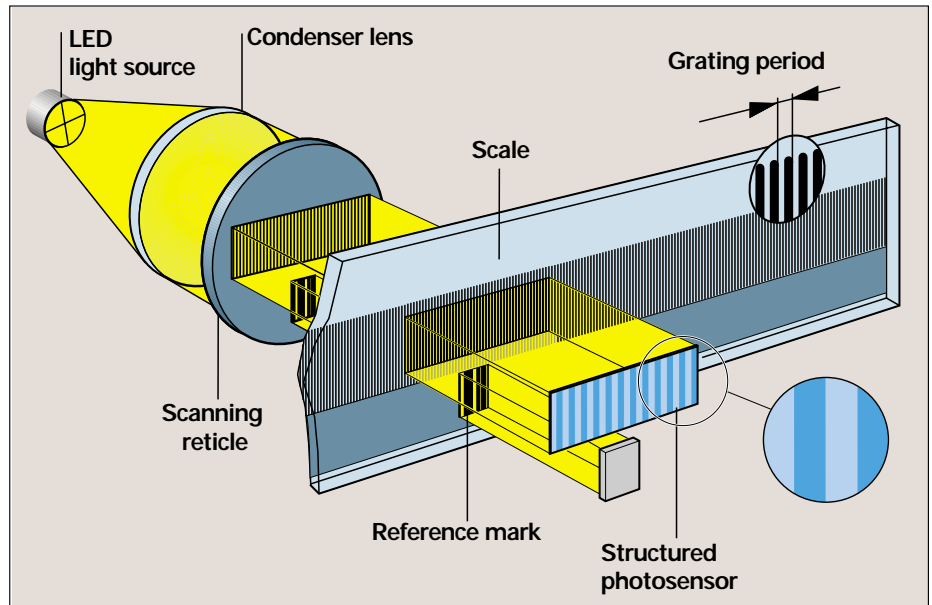

Photoelectric scanning in accordance with the imaging principle and single-field scanning

Better signal quality

Sealed linear encoders acquire their accuracy first of all from the high quality of the line grating on the glass scale. Its grating period is 20 µm and permits measuring steps down to 0.1 µm and finer, which can be produced by interpolation.

The newly developed scanning optics has considerable influence here. The large scanning field and the special optical filtering generate scanning signals with constant signal quality over the entire path of traverse. This is the prerequisite for:

- Small position error within one signal period
- High traversing speed
- Good control quality for direct drives

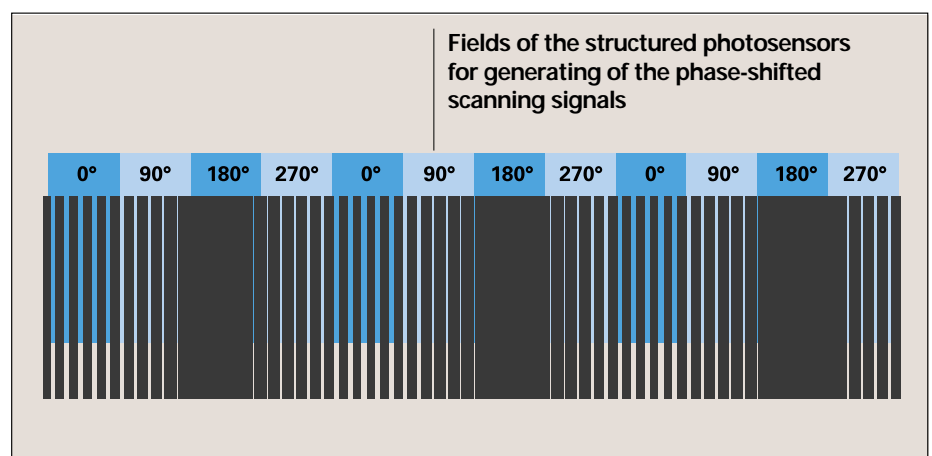

Imaging the light/dark fields of the scanning reticle and scale on the structured photosensor

Benefits of Single-Field Scanning

Insensitive to contamination

The large scanning area over the entire width of the scale grating and the arrangement of several scanning fields in succession make the encoders with single-field scanning extremely insensitive to contamination. The results of corresponding contamination tests prove this: even when contamination over large areas is simulated, the encoder continues to provide high-quality signals. The position error remains far below the value specified for the accuracy grade of the encoder.

In many cases, depending on the contamination, this can even prevent encoder failure where 4-field scanning cannot.

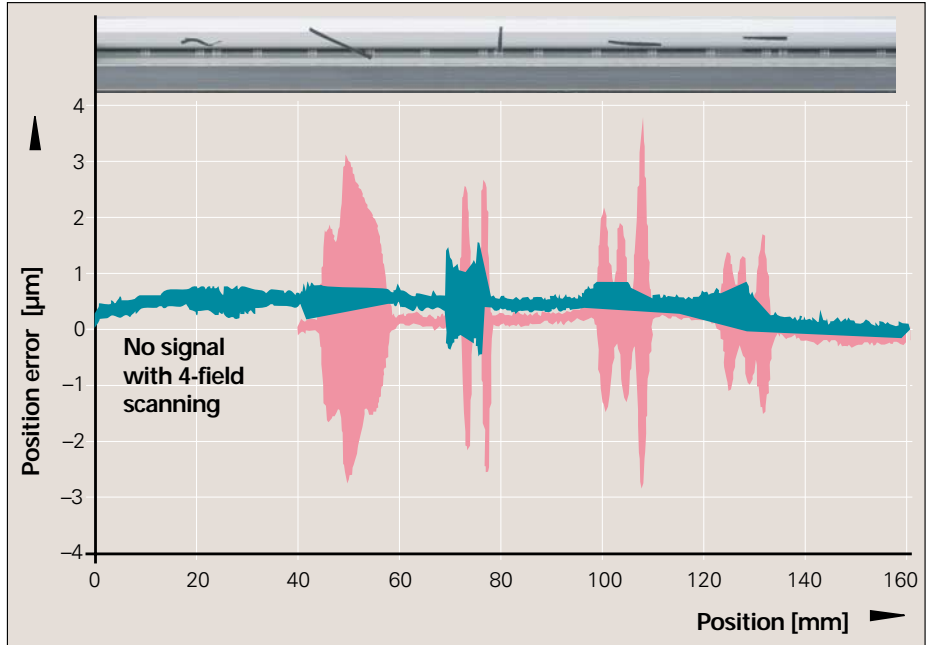

Effects of contamination with 4-field scanning (red) and single-field scanning (green)

This example shows the influence of contamination on the output signals.

In the XY representation on an oscilloscope the signals form a Lissajous figure. Ideal output signals appear as a concentric inner circle. Deviations in circular form and position are caused by position error within one signal period (see *Measuring Accuracy*) and therefore go directly into the result of measurement. The size of the circle, which corresponds with the amplitude of the output signal, can vary within certain limits without influencing the measuring accuracy.

This type of contamination has very striking effects with 4-field scanning: Because two scanning fields are involved, the XY display shows an extremely eccentric ellipse. This causes a total failure of the encoder at this position. In the encoder with single-field scanning, however, one sees only a small change in the amplitudes. In the XY display, only the diameter changes slightly—a sure sign of very low position error.

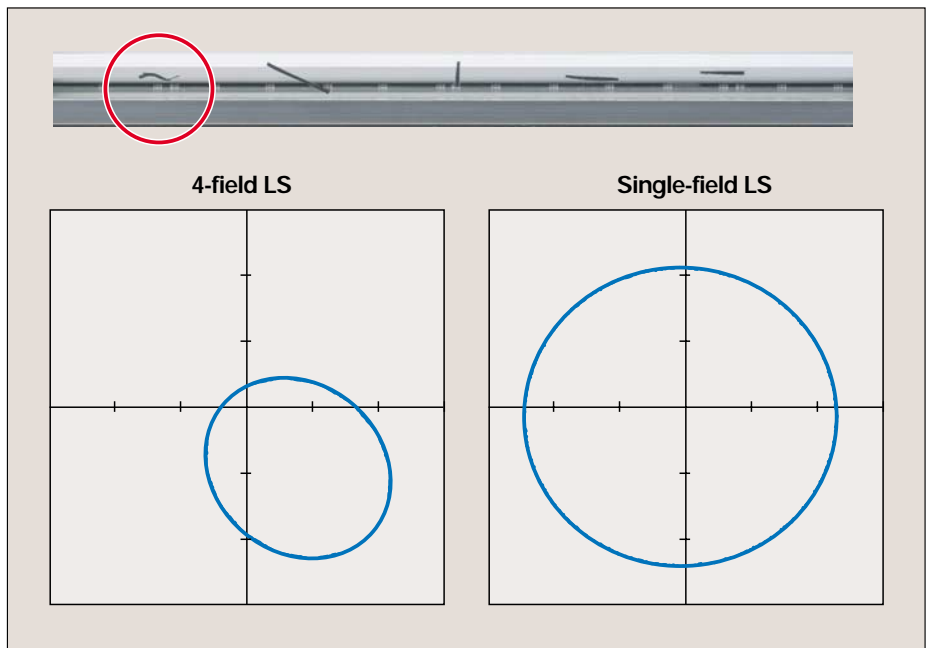

Linear encoders with single-field scanning can withstand even extreme conditions. As, for example, in the splash test. Here HEIDENHAIN tests its encoders in continuously repeated cycles:

- 12 hours traverse under massive use of coolant
- 12 hours rest and cooling off

The tests also show that condensation on the scale during the cooling-off phases has practically no effects on the function of the encoder.



Splash test unit with slimline linear encoder

Traversing Speed

The permissible traversing speed of sealed linear encoders depends on

- the mechanically permissible traversing speed, and
- the electrically permissible traversing speed.

High traversing speeds are required particularly when linear encoders are used on laser cutting machines, direct drives, for example.

Mechanical characteristics

The sealing lips of sealed linear encoders function with very little friction. This permits high traversing speeds with consistently low wear.

Electrical characteristics

Single-field scanning provides output signals with high quality and constancy. Their amplitudes depend only to a small degree on the traversing speed. This guarantees stable output signals for consistently good interpolation, even at high traversing speeds.

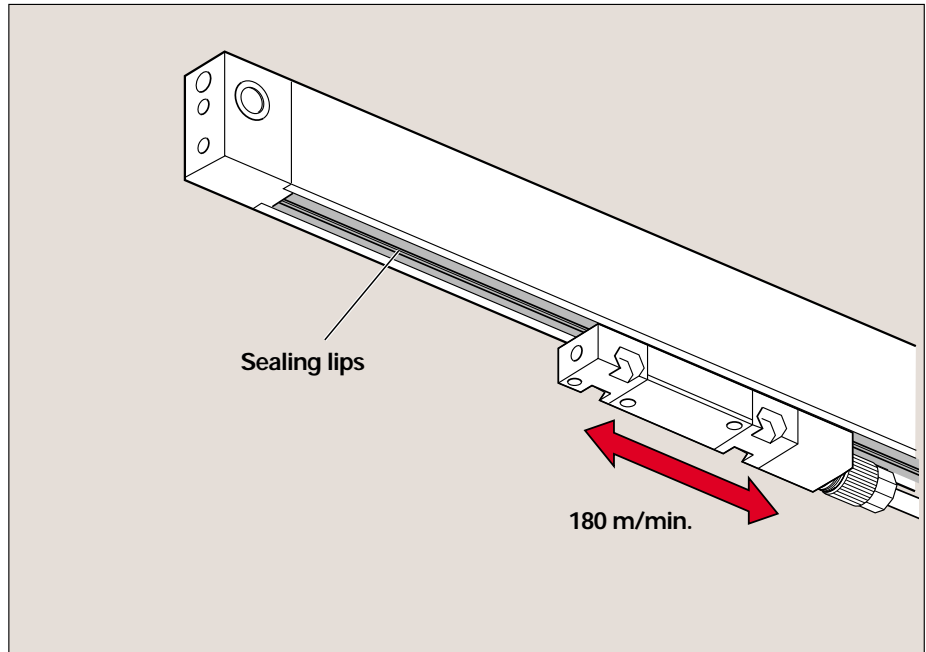
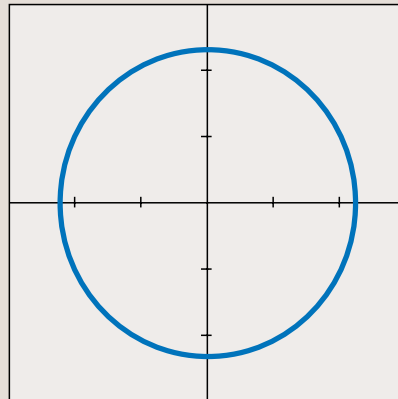
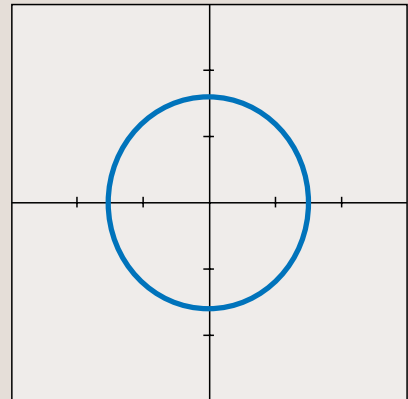
**Low traversing speed****High traversing speed**

Accuracy

The accuracy of linear encoders is mainly determined by:

- The quality of the graduation
- The quality of scanning

A distinction is made between position error over relatively large paths of traverse, for example the measuring range, and that within one signal period.

The **position error over the measuring range** is determined primarily by the accuracy of the graduation. They are documented in the calibration chart. On the other hand, the **position error within one signal period** depends on the quality of the scanning and the signal period. This error occurs during the interpolation of the sinusoidal output signals because of asymmetric signals and deviations from the sinusoidal form. Position error within one signal period is random and therefore cannot be compensated. It has effects, for example, on the quality of servo control for the drives and on the repeatability.

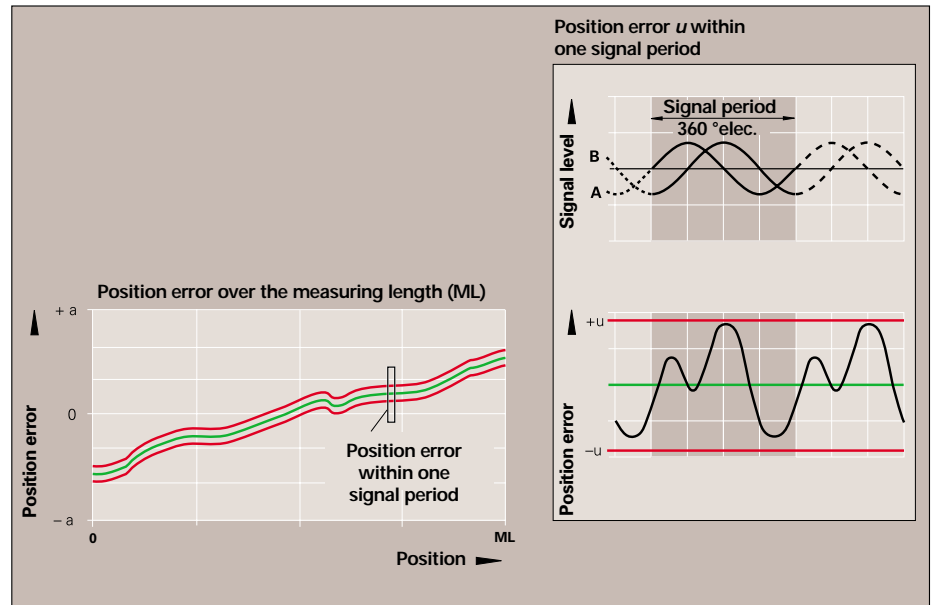

Thanks to its special optical filtering and its large scanning field, single-field scanning provides signals with high constancy and good sinusoidal form. This substantially reduces position error within the signal period. This is very visible on the XY display on the oscillogram: The output signals of the linear encoders with single-field scanning showed a more circular form and less signal noise.

This reflects higher positioning accuracy and higher control quality, which means improved, finely tuned velocity control on direct drives.

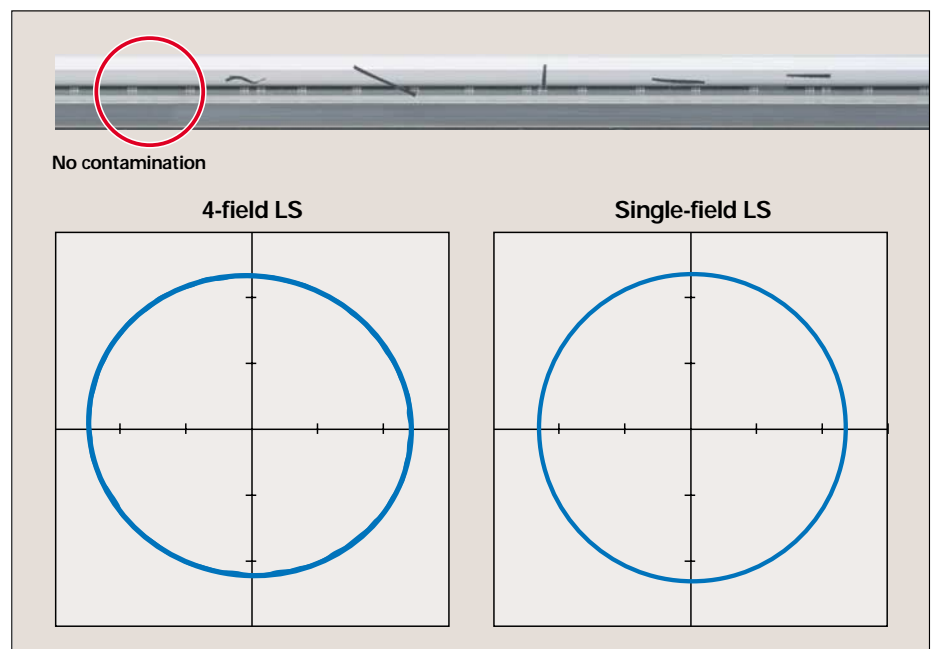

DR. JOHANNES HEIDENHAIN GmbH develops and manufactures linear and angular encoders, rotary encoders, digital readouts, and numerical controls for machine tools. HEIDENHAIN supplies its products to manufacturers of automated machines and systems, in particular for semiconductor and electronics manufacturing.

HEIDENHAIN is represented in 43 countries—mostly with wholly owned subsidiaries. Sales engineers and service technicians support the user on-site with technical information and servicing.



HEIDENHAIN

DR. JOHANNES HEIDENHAIN GmbH

Dr.-Johannes-Heidenhain-Straße 5

83301 Traunreut, Germany

☎ +49 (8669) 31-0

☎ +49 (8669) 50 61

e-mail: info@heidenhain.de

www.heidenhain.de