

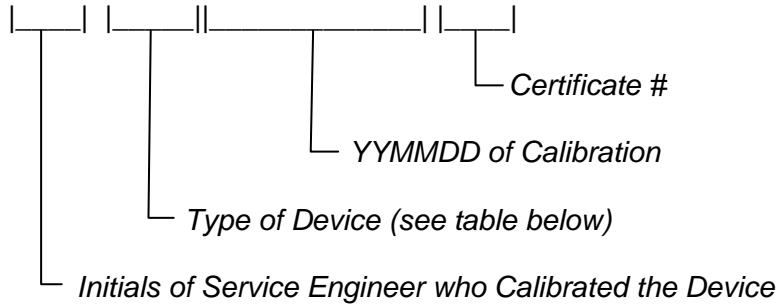

ATI Cert Key

JJ-OD060725-01



CODE	DESCRIPTION
AB	Angle Blocks
AG	Angle Gage
BG	Bore Gage
C	Caliper
CC	Chamfer Chek
CP	Cylindrical Pin / Plug Gages
DM	Depth Micrometer
DT	Drop Tester
DU	Durometer
FG	Force Gage, Feeler Gage
HC	Hole Chek
HG	Height Gage
HT	Hardness Tester
I	Indicator
L	Level
LB	Light Booth
LM	Laser Mic
LO	Layout Table
LS	Length Standard
M	Micrometer
MF	Measuring Filar Microscope
MM	Magna Mic
MP	Magnetic Particle Machine
MR	Measuring Reticle Microscope

CODE	DESCRIPTION
MT	Magnification Check Scale, Target
OD	Optical Device (Comparator, etc.)
PG	Pressure Gage
PP	Plain Plug
PR	Protractor, Plain Rings
R	Rule
RG	Radius Gages
SC	Scales
SF	Coordinate Measuring Machine
SM	Setting Masters
SP	Surface Plate
SQ	Square
SR	Surface Roughness Tester
TA	Taper Gage
TE	Temperature, Ovens
TP	Thread Plug
TR	Thread Ring
TG	Torque Tools
TW	Thread Wire
VB	V Blocks
VD	Video Device (Manual w/DRO)
VG	Automated MicroVu Video
WS	Weight Scale